



AIL **TRUNNION MOUNTED** **BALL VALVES**

SOFT SEATED & METAL SEATED

ASME Class 150 - 2500

2" - 56" (50mm - 1400mm)

API 6D



AUDCO INDIA LIMITED

AIL Trunnion Mounted Ball Valves are of 2-piece / 3-piece design, with flanged or butt-weld ends. As a standard, the valves are manufactured in 2-piece bolted body designs, where the joint between the body and the connector is bolted. The bolted body design offers flexibility for dismantling during field service in case of an emergency. Welded body designs, where the joint between the body and connector is welded, are also available on request.

AUDCO INDIA LIMITED (AIL) is a leading valve manufacturer, with a strong presence in India and overseas.

AIL has four manufacturing facilities located in Southern India. Apart from the main plant located in Manapakkam, Chennai, two other plants are at Maraimalai Nagar, 40 kilometres south and at Kancheepuram, 70 kilometres west of the main plant. The fourth plant is located at Coimbatore, Tamil Nadu. These plants are equipped with modern manufacturing facilities with special-purpose machines, automatic welding equipment, heat treatment furnaces and testing equipment for total control of all manufacturing operations. In-house metallurgical, NDE and calibration facilities with modern equipment provide support to ensure the quality of products manufactured.

AIL manufactures a wide variety of industrial valves. The Quality Management System in all four plants is certified to ISO 9001:2000 System.

Table of Contents

Content	Page No.
Introduction	03
<i>Quality Policy</i>	03
<i>Quality Assurance</i>	03
<i>Compliance Certificates</i>	03
<i>Manufacturing Programme</i>	03
Soft seated Valves	04 - 08
<i>Standard Features</i>	04 & 05
<i>Seat Design</i>	06
<i>Optional Features</i>	07
<i>Exploded View</i>	08
Metal seated Valves	09 & 10
<i>Exploded View</i>	09
<i>Standard/Optional Features and Seat Design</i>	10
Technical Information	11
<i>Pressure Rating</i>	11
<i>Compliance Standards</i>	11
<i>Alternate Materials of Construction</i>	11
<i>Seat Material selection & parameters</i>	11
Dimensional Details	
<i>ASME Class 150, 300 and 600</i>	12 & 13
<i>ASME Class 900, 1500 & 2500</i>	14 & 15
AIL Metal seated Trunnion Mounted Ball Valve 3-piece fully-welded	16 & 17
Ordering Information	19

Chennai plant



Quality Policy

Audco India Limited is committed to Total Customer Satisfaction

We achieve this by

- Maintaining a high standard of quality consistent with the customer requirements
- Complying with the Codes, Standards, Customer Specifications, Statutory and Regulatory requirements as applicable to our products
- Continually improving the effectiveness of Quality Management System to add value to our products

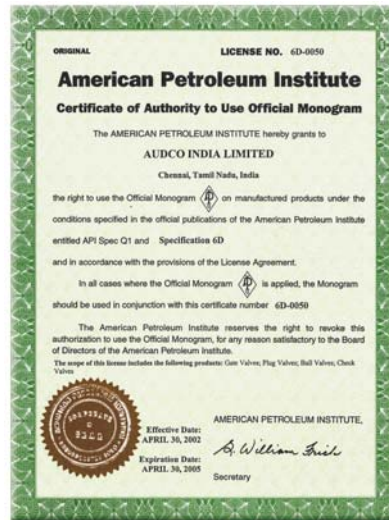

Quality Assurance

The name AIL is synonymous with quality-assured products all over the world. This reputation has been achieved over decades of careful attention to quality control and assurance activities. AIL Trunnion Mounted Ball Valves are manufactured as per the requirements of API 6D and can be supplied with the API 6D monogram, if required. The entire manufacturing process follows as laid down in the Company Quality Assurance Manual and complies with the requirements of ISO 9001:2000 and API Spec Q1.



AIL Manufacturing Programme

Seat Design	End Conn.	ASME Class	VALVE SIZE (in inches)																			
			2	3	4	6	8	10	12	14	16	18	20	22	24	28	30	36	42	48	56	
SOFT SEATED	FLANGED RF	150	●	●	●	●	●	●	●	●	●	●	●	●	●	●	●	●	●	●	●	
		300	●	●	●	●	●	●	●	●	●	●	●	●	●	●	●	●	●	●	●	●
		600	●	●	●	●	●	●	●	●	●	●	●	●	●	●	●	●	●	●	●	●
		900	●	●	●	●	●	●	●	●	●	●	●	●	●	●	●	●	●	●	●	●
		1500	●	●	●	●	●	●	●	●	●	●	●	●	●	●	●	●	●	●	●	●
	2500	●	●	●	●	●	●	●	●	●	●	●	●	●	●	●	●	●	●	●	●	●
	BUTT-WELD	150	●	●	●	●	●	●	●	●	●	●	●	●	●	●	●	●	●	●	●	●
		300	●	●	●	●	●	●	●	●	●	●	●	●	●	●	●	●	●	●	●	●
		600	●	●	●	●	●	●	●	●	●	●	●	●	●	●	●	●	●	●	●	●
		900	●	●	●	●	●	●	●	●	●	●	●	●	●	●	●	●	●	●	●	●
		1500	●	●	●	●	●	●	●	●	●	●	●	●	●	●	●	●	●	●	●	●
	2500	●	●	●	●	●	●	●	●	●	●	●	●	●	●	●	●	●	●	●	●	●
FLANGED RTJ	600	●	●	●	●	●	●	●	●	●	●	●	●	●	●	●	●	●	●	●	●	
	900	●	●	●	●	●	●	●	●	●	●	●	●	●	●	●	●	●	●	●	●	
	1500	●	●	●	●	●	●	●	●	●	●	●	●	●	●	●	●	●	●	●	●	
	2500	●	●	●	●	●	●	●	●	●	●	●	●	●	●	●	●	●	●	●	●	
METAL SEATED	FLANGED RF	150	●	●	●	●	●	●	●	●	●	●	●	●	●	●	●	●	●	●	●	
		300	●	●	●	●	●	●	●	●	●	●	●	●	●	●	●	●	●	●	●	●
		600	●	●	●	●	●	●	●	●	●	●	●	●	●	●	●	●	●	●	●	●
	BUTT-WELD	150	●	●	●	●	●	●	●	●	●	●	●	●	●	●	●	●	●	●	●	●
		300	●	●	●	●	●	●	●	●	●	●	●	●	●	●	●	●	●	●	●	●
		600	●	●	●	●	●	●	●	●	●	●	●	●	●	●	●	●	●	●	●	●
FL RTJ	600	●	●	●	●	●	●	●	●	●	●	●	●	●	●	●	●	●	●	●	●	

AIL Soft Seated Trunnion Mounted Ball Valves

Standard Features

Bolted Body Construction

As a standard, the valves are manufactured in 2-piece bolted body designs, where the joint between the body and the connector is bolted.

Double Block and Bleed

AIL Trunnion Mounted Ball Valves are designed for upstream sealing, so that the double block and bleed features are automatically built in.

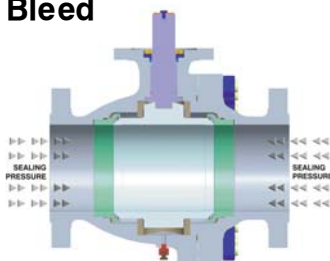

The feature enables **on-line affirmation** of proper seat sealing. The load generated by the line fluid on ball is absorbed by the trunnion bearings and is directly transmitted to the valve body. The valve stem is hence free from any bending load which leads to reduced stem friction torque and enhanced stem seal life. The seat rings are allowed to float in the flow axis against a fixed ball so that the line pressure assists in pressing the spring-loaded upstream seat against the ball. Thus, the operating torque and wear on the seats is relatively low, enhancing seat life.

Cavity Relief

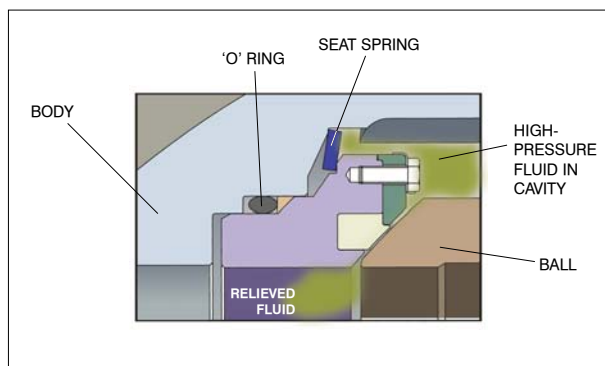

The seat design has a built-in automatic cavity relief mechanism. In the event of excessive pressure build-up inside the cavity, the springs that keep the seats pressed to the ball are pressed back by the seat, allowing the release of excessive pressure. This eliminates the need for having external cavity relief assemblies.

Fire-safe design

AIL Trunnion Mounted Ball Valves are fire-safe by design in accordance with API 6FA - Specification for Fire Test for Valves (equivalent to ISO 10497) and API 607 - Fire Test for Soft Seated Quarter-Turn Valves. AIL has successfully fire-tested the valves in-house, witnessed and certified by Lloyds Register. These valves have been supplied in large quantities for crude/gas pipelines, and in petrochemical and allied industries where fire hazard is an important consideration.

Blowout-proof Stem

AIL Trunnion Mounted Ball Valves have a bottom-entry stem design, where the stem is inserted from inside the body. An integral shoulder on the stem butts against a shoulder in the body, giving it blowout-proof integrity. The higher the line pressure, the tighter the seal. This design offers safety features superior to those of top-entry stem designs where the line pressure works to break the stem seating. This feature also allows online replacement of the gland packing, in case of an emergency.

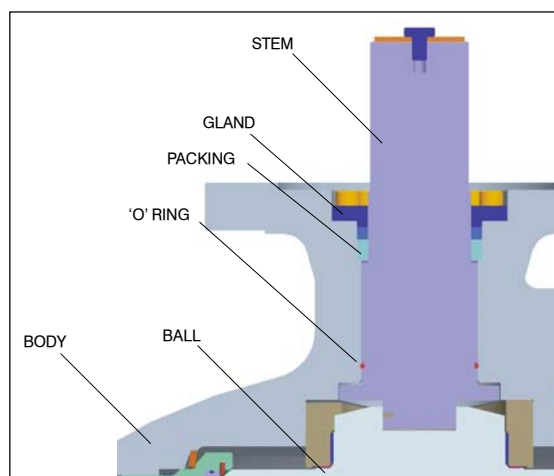

Blowout-proof Stem and Stem Sealing arrangement

Stem sealing - assured safety

A high integrity sealing system is provided on the stem for assured protection to the atmosphere.

- An elastomer seal in the form of an 'O' ring is located at the lower end of the stem which provides the first level of protection to the atmosphere.
- Pre-compressed and pressure-energised graphite gland packings are provided at the upper portion of the stem.
- The design provides for stem sealant injection (optional) between the elastomer seal and the gland packing for valve of sizes 8" and above, which gives the third level of protection.

Vent and Drain

Valves are provided with vent and drain connections for venting/draining of the valve cavity. These are normally NPT-threaded plugs with bleed facility. In addition to this, the connections can be provided with isolation valves (ball valves) on specific customer requirement. Vent and drain connections can also be used for on-line affirmation of valve sealing.

Compact internal trunnion holder

The internal trunnion holders in the valve eliminate many drawbacks arising from valve designs that feature external trunnion holders. An

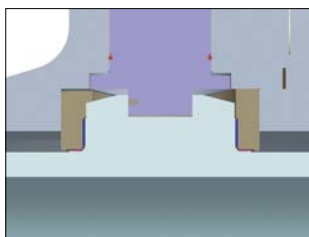

entire path of leakage to the atmosphere is eliminated, which otherwise needs to be taken care of in external trunnion designs. Further, the scope for accidental damage to the trunnion holder in the external design, in which the trunnion cover projects out of the valve body, is eliminated in the internal trunnion holder design.

End Connections

AIL Trunnion Mounted Ball Valves come with a variety of end connections:

Flanged : As standard features, valves with ASME Class ratings of 150, 300 and 600 come with Raised Face (RF) flanges with serration and of finish 125-250 AARH. Valves with ASME Class ratings of 900, 1500 and 2500 come with Ring-Type Joint flanges. As an option, valves with ASME Class rating of 600 can also be supplied with Ring-Type Joint flanges. RF flange finishes such as 32-63 AARH, 63-125 AARH and extra-smooth can be supplied on request.

Butt-weld : Valves can be supplied with butt-weld ends (BWE), with schedule as per customer requirement. Valves can also be supplied with a combination of any of the above mentioned ends (like, one end flanged and the other butt-welded).

Hub : Valves with hub ends to suit specific clamp manufacturers' designs can also be supplied.

Actuator Mounting Flange

The valves come with an integral mounting flange with drilled holes suitable for mounting gear units and actuators. The mounting flange conforms to ISO 5211.

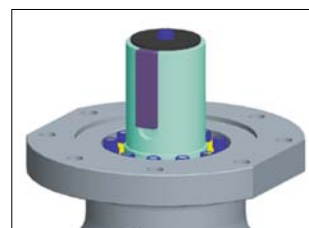

Lifting Lugs and Foot Support

Valves of sizes 8" and above are provided with lifting lugs and foot support.

Operating Devices

Valves can be provided with any of the following operating devices: lever/gear operated for manual operation, electrical actuators, gas/pneumatic actuators and gas-over-oil actuators. The table shown below indicates the range of valves operable by lever/gear.

ASME Class	Mode of operation	
	Lever	Gear
150	2" - 6"	8" and above
300	2" - 4"	6" and above
600	2" - 3"	4" and above
900	2"	3" and above
1500	2"	3" and above
2500	-	2" and above

AIL can also supply integrated packages consisting of Trunnion Mounted Ball Valves with actuators of customers' choice. Furthermore, all necessary control systems can be integrated with the actuator. FAT (Factory Acceptance Test) is conducted on these valves with actuators at AIL's facility. Of these actuators, the gas-over-oil variant finds applications mostly in cross-country pipelines where compressed air supply is unavailable. This actuator functions by using the gas from the pipeline. AIL has gained in-depth experience in supplying actuated valves for several projects, particularly for Shut-Down Valves (SDVs) and Emergency Shut-Down Valves (ESDVs).

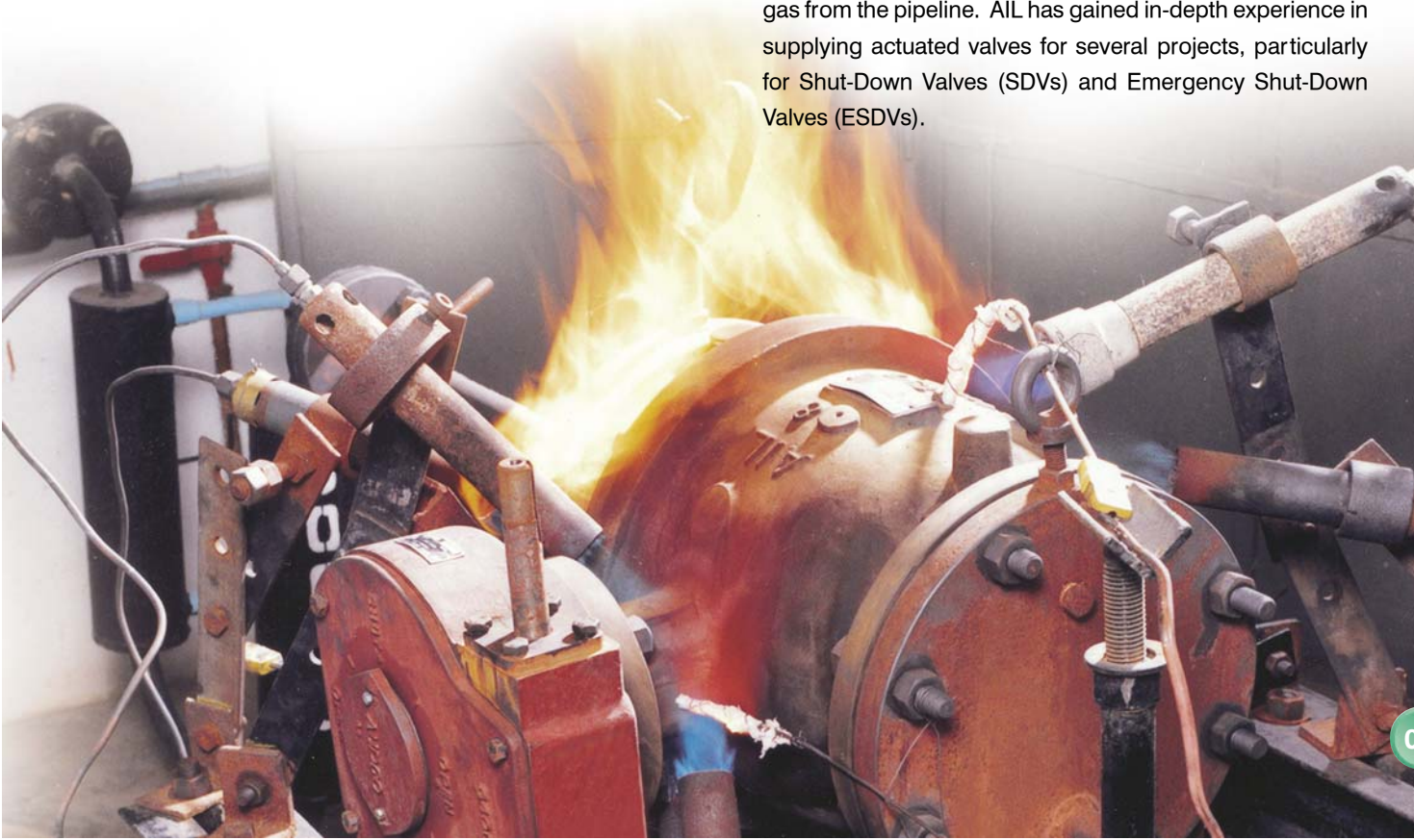

Seat Design

Sealing is achieved by contact of the soft seat with the spherical surface of the ball. The soft seat is positioned in a groove drawn in the metallic seat ring/housing. The soft seat is always kept in contact with the ball by the spring load acting on the seat ring.

Spring load is achieved by means of a seat spring (flat annular plate) compressed in assembly, providing a uniform load on the seat ring. This ensures uniform contact of the seat with the ball.

In addition to the spring load, the net pressure load acting on the back of the seat ring (annular area between the outer diameter of the seat ring and the inner diameter of sealing of the soft seat) produces a piston effect on the seat ring to enhance the sealing between the soft seat and the ball. In the event of fire where the soft seat is likely to burn out, the spring load ensures adequate contact of the seat ring with the ball to provide the required sealing.

The sealing between the seat ring and the body/body connector is effected by means of an elastomer 'O' ring. In addition to this, a metal wedge ring is provided to ensure sealing in case of fire that could damage the 'O' ring.

The seat spring is designed in such a way that

- It ensures adequate load on the seat to provide the required sealing, particularly at lower pressures.
- It allows for automatic relief of excess pressure in the valve cavity.

As the valve is opened or closed under differential pressure, the soft seat can experience imbalance in forces acting across local seat sections. To prevent dislodging of the seat due to this effect, a bolted or a split retainer ring is deployed to hold it in position. In higher pressure classes, upon assembling the soft seat, the seat ring is crimped (mechanically deformed) to prevent the seat from coming out. This is a viable alternative, particularly in the case of higher pressure levels.

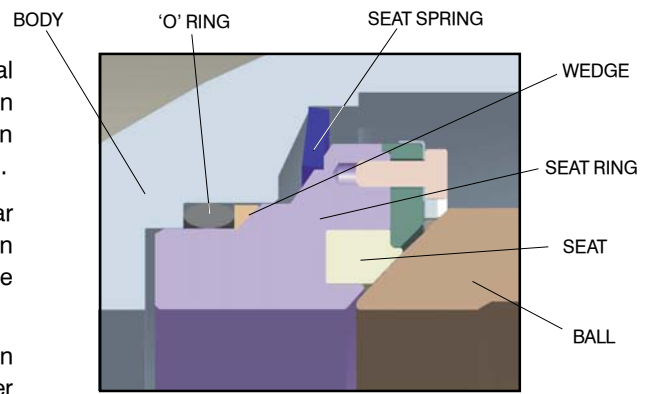

Seat design for Classes 150 and 300

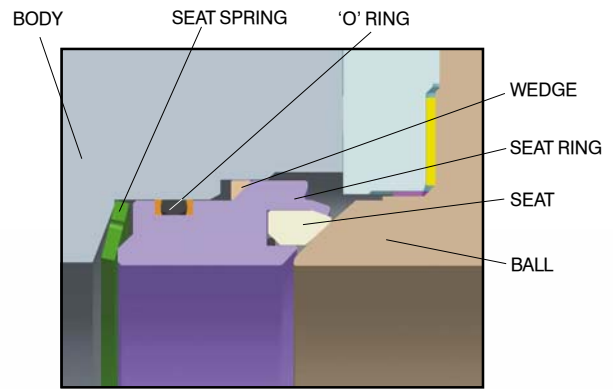

Seat design for Classes 600, 900, 1500 and 2500

*24" Full Bore Class 600 Welded construction
Gas-over-Oil Actuator operated
Metal-seated Trunnion Mounted Ball Valve*

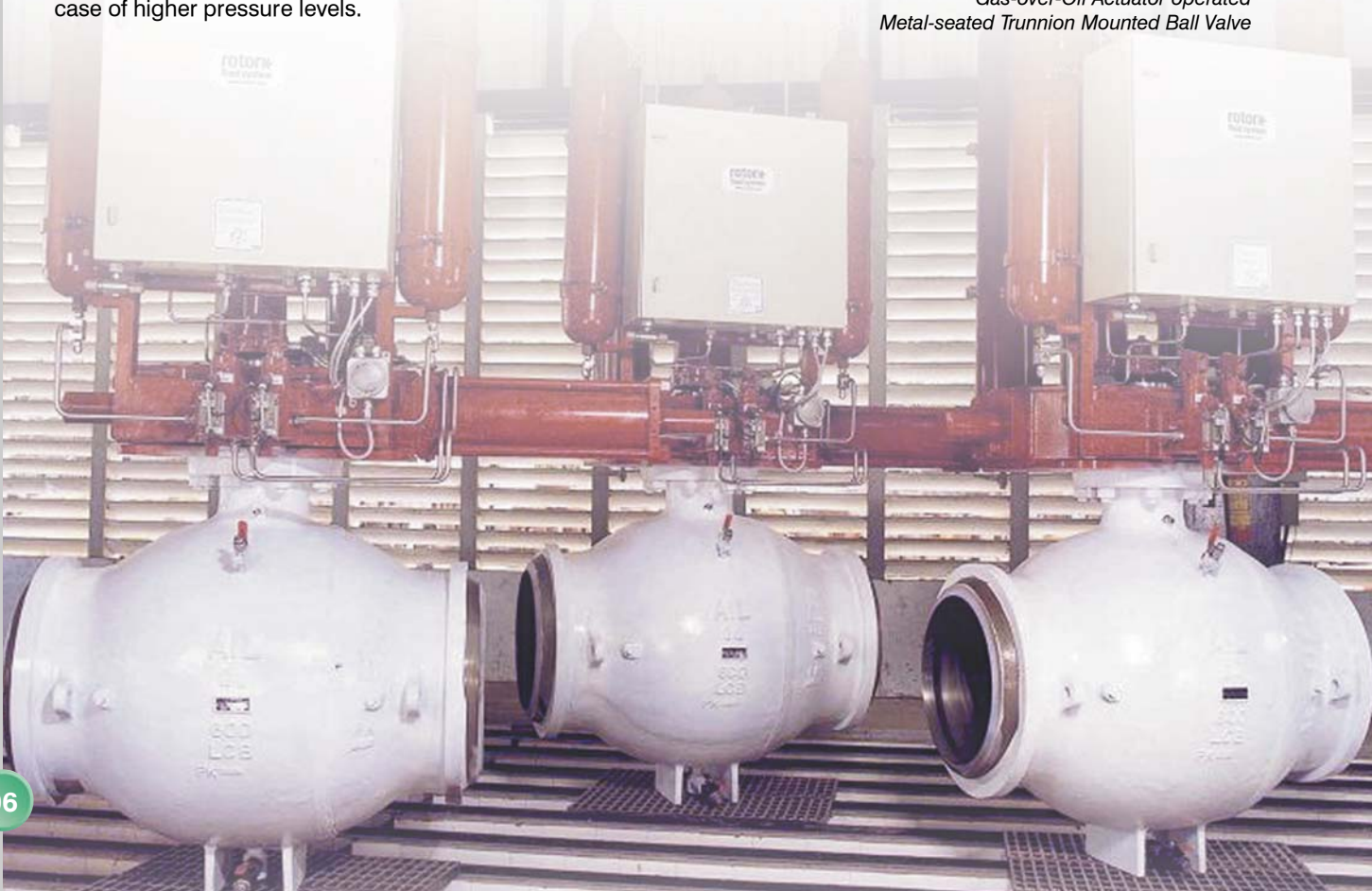

AIL Soft Seated Trunnion Mounted Ball Valves

Optional Features

Fully-welded Body design

This design, available as a variant of the bolted-body configuration, features the body and the body connector being welded at the interface after the valve is fully assembled. The welding is performed by qualified welders as per statutory welding procedures complying with relevant ASME codes. This design is specially suited for buried service applications and in instances where leakage to the atmosphere is strictly non-permissible.

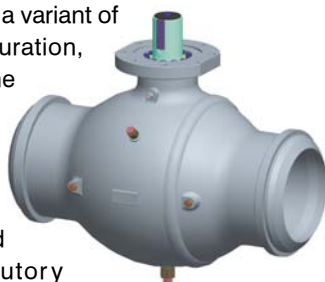

Sealant Injection System

A renewable seal is provided for valves in sizes of 8" and above in the form of a fully-contained sealant injection system, which also serves as an emergency backup in case of damage to other sealing members.

Extended Stem Arrangement

Valves can be supplied with stem extension arrangement, which finds application in buried services or where the valve operation is operated at a considerable depth/height. The height of the extension from the valve centre-line or from the valve cover flange top should be specified by the customer. Where applicable, vent/drain connections and sealant connections are brought up close to the operator through suitable pipes for ease of access.

Pup piece / Transition Pipe

Butt-weld end valves can be welded with pup pieces for ease of valve erection at site. This results in minimal heat transfer to the valve internals while welding it to the pipeline.

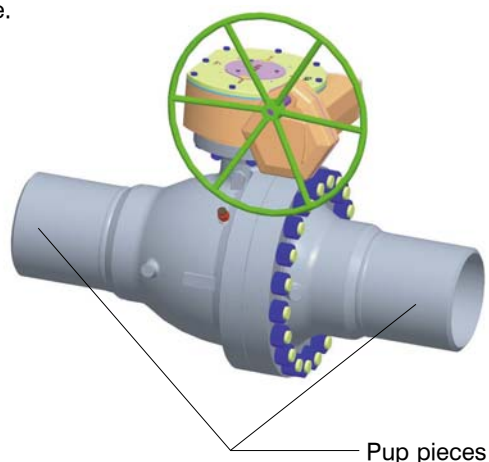

Weld Overlay and Coatings

On request, AIL can supply valves with weld overlay in the seat and stem seal pockets with materials such as Inconel or Stellite. These areas can also be coated with ENP.

Double Piston Seat Design

This is a unique seat design which allows the downstream seat to seal with pressure acting from the upstream side of the valve. In case the upstream seat is damaged, the fluid enters the valve cavity, goes behind the downstream seat and pushes the downstream seat on to the ball. This is a bidirectional feature.

Locking Arrangement

Valves can be supplied with locking arrangement, if required. This arrangement can be used to lock the valves in either the open or closed position.

CE and ATEX marking

Valves can be supplied with CE marking - a mandatory requirement for shipments to European markets. These valves can also be supplied with ATEX marking.

'O' Rings with AED properties

Anti-Explosive Decompression (AED) helps in minimising the chances of an 'O' Ring bursting at very high pressures. Valves can be supplied with 'O' Rings having AED properties.

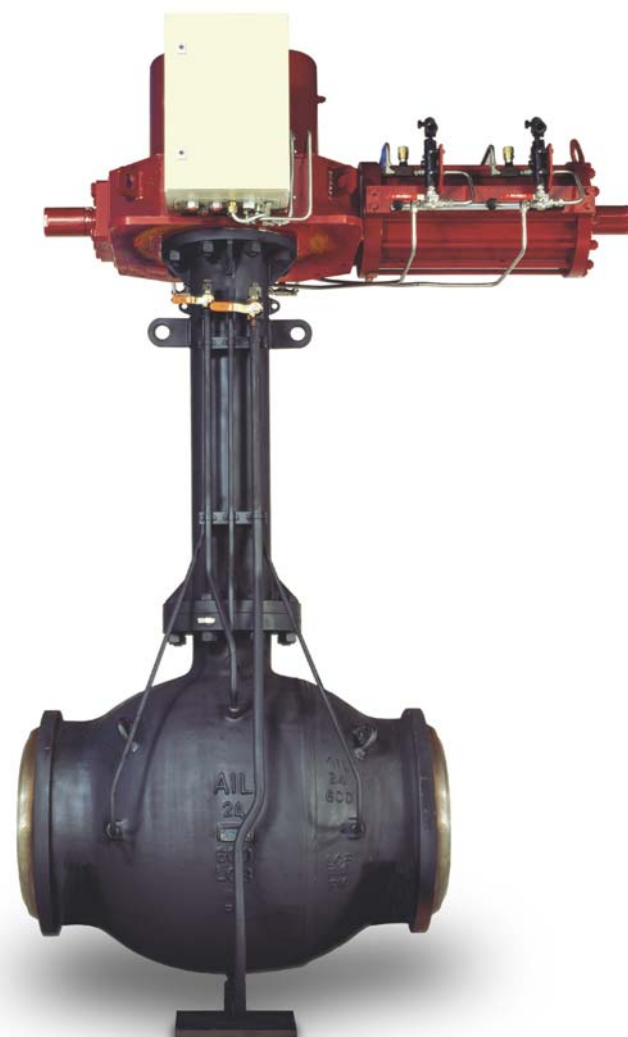

Exploded View of Metal Seated Trunnion Mounted Ball Valve

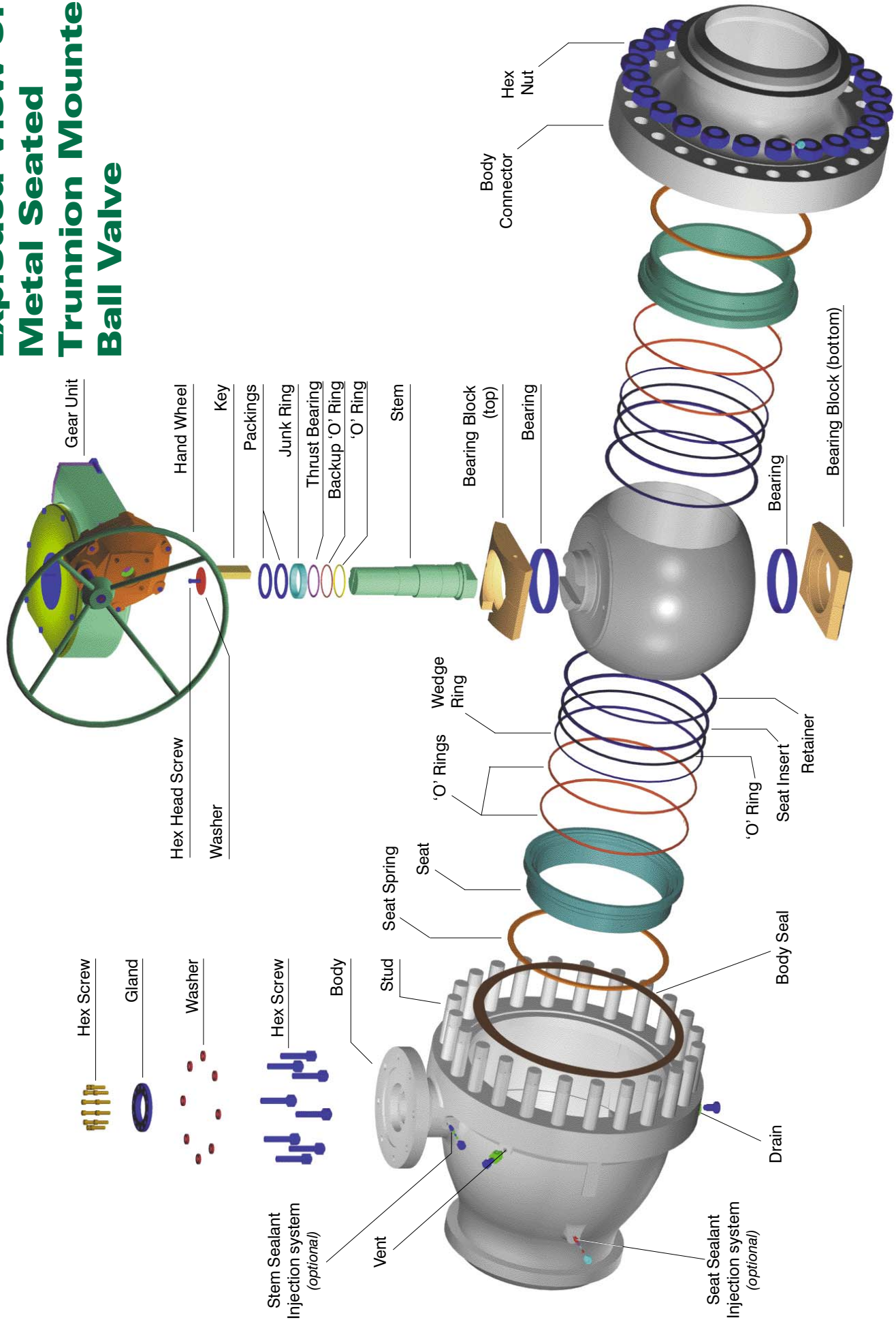

AIL Metal Seated Trunnion Mounted Ball Valves

Standard Features

- Bolted Body Construction
- Double-Block and Bleed
- Cavity Relief
- Blowout-proof stem
- Stem Sealing - assured safety
- Vent and Drain
- Compact Trunnion holder
- Valve End Connections
- Actuator Mounting Flange
- Lifting Lugs and Foot Support
- Operating Devices

For details, refer pages 4 and 5.

Sealant Injection System

A renewable seal is provided for valves in sizes of 8" and above in the form of a fully-contained sealant injection system, which also serves as an emergency backup in case of damage to other sealing members.

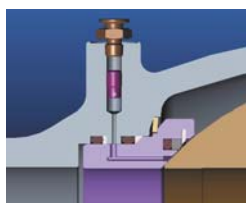

Fire-safe by design

AIL Trunnion Mounted Ball Valves are fire-safe by design in accordance with API 6FA - Specification for Fire Test for Valves (equivalent to ISO 10497). AIL has successfully fire-tested the valves in-house, witnessed and certified by Lloyds Register. These valves have been supplied in large quantities for crude/gas pipelines, and in petrochemical and allied industries where fire hazard is an important consideration.

Metal Seat Design

Sealing is achieved by simultaneous contact of the soft seat insert and the metal seat ring with the spherical surface of the ball. The soft seat insert is positioned in a groove drawn in the seat ring and is backed by an elastomer 'O' ring in a compressed condition to ensure contact with the ball. Furthermore, a large metal-to-metal sealing land is provided between the seat ring and the ball inside the soft seat area as a result of the spring load acting on the seat ring.

Spring load is achieved by means of a seat spring (flat annular plate) compressed in assembly, providing a uniform load on the seat ring. This ensures uniform contact of the seat with the ball.

In addition to the spring load, the net pressure load acting on the back of the seat ring (annular area between the outer diameter of the seat ring and the inner diameter of sealing of the metal seat) produces a piston effect on the seat ring to enhance the sealing between the seat ring and the ball. The sealing between the seat ring and the body/body connector is effected by means of an elastomer 'O' ring.

In addition to this, a metal wedge ring is provided to ensure sealing in case of fire that could damage the 'O' ring. To prevent the sealant from flowing through the back of the seat ring, an additional 'O' ring (with

backup ring for ASME Class 600 rating and above) is provided.

The seat spring is designed in such a way that

- It ensures adequate load on the seat to provide the required sealing, particularly at lower pressures.
- It allows for automatic relief of excess pressure in the valve cavity.

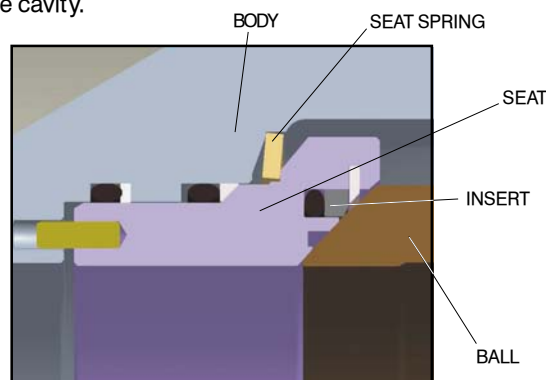

TMBV Seat design for Classes 150, 300 and 600
(Sealant Injection system for 8" valves and above)

As the valve is opened or closed under differential pressure, the soft seat can experience imbalance in forces acting across local seat sections. To prevent dislodging of the seat due to this effect, a split retainer ring is deployed to hold it in position, being fitted in a radial groove, axially retaining the soft seal insert. Also, the retainer ring helps precisely control the maximum insert projection thereby preventing damage as the valve is operated.

Dimensional details for these valves are the same as those for their soft seated counterparts in Class 150, 300 and 600 respectively, featured in pages 12 and 13.

Optional Features

- Double-piston Seat design
- CE and ATEX marking
- 'O' Rings with AED properties
- Pup-piece/Transition Pipe
- Locking and Extension arrangements
- Fully-welded Body design

For details, refer page 7.

Special Services

AIL can offer fully metal seated designs in which soft seats are absent and the sealing is effected purely by means of metallic contact between the ball and the seat ring. These designs find application in services that warrant high temperature as well as in abrasive or erosive conditions. The contact surfaces here are hardfaced with coatings such as Chromium Carbide, Tungsten Carbide and Stellite. For high temperature service, the sealing between the seat ring and body/body connector is achieved by means of live-loaded graphite seals.

Compliance Standards

Parameter	Conformity
Valve Design	API 6D
Pressure-Temperature Rating	ASME B16.34
Face-to-Face Dimension	ASME B16.10
End Flanges	ASME B16.5 / ASME B16.47 Series A*
Butt-Weld Ends	ASME B16.25 (Schedule as per customer requirement)
Valve Inspection and Testing	API 6D / API 598

* For valves larger than 24" (600mm), the flange drilling shall be as per ASME B16.47 Series A (MSS SP 44).

Alternate Materials of Construction (Soft Seated and Metal Seated)

Sl. No.	Description	Alternate Materials
1	Body	WCC, LCB, CF8, CF8M, Alloy 20, Duplex SS
2	Body Connector	WCC, LCB, CF8, CF8M, Alloy 20, Duplex SS
3	Ball	WCB + PTFE / ENP, CF8, CF8 + ENP, CF8M, CF8M + ENP, CA 15 Alloy 20
4	Seat Housing	SS 4140 + PTFE/ENP, WCB + PTFE / ENP, CF8, CF8 + ENP, CF8M, CF8M + ENP, ASTM A395 + PTFE / ENP, Alloy 20
5	Seat	See table on seat material selection
6	Stem	SS 316, SS 4140 + ENP, SS 304, Alloy 20, 17-4PH, Monel, F51
7	'O' Rings	Viton
8	Bolts / Nuts	B8 / Gr. 8, L7 / Gr. 7, Duplex SS

Seat material selection

Seat Design	ASME Class	Seat Material	
		Standard	Alternate
Soft Seated	150, 300	PTFE	RPTFE
	600	NYLON	RPTFE / PEEK
	900, 1500, 2500	NYLON	PEEK
Metal Seated	150, 300, 600	NYLON	PEEK

Pressure Testing

Valve Rating	Shell (hydro)		Seat (hydro)	
	kg/cm ²	psi	kg/cm ²	psi
150	32	450	22	315
300	79	1125	58	815
600	157	2225	115	1630
900	236	3350	172	2445
1500	396	5575	287	4080
2500	649	9280	475	6790

Optional low pressure AIR SEAT test at 80 psi is conducted, if specifically called for.

Allowable Temperature Limits for various seat materials with different 'O' Ring combinations

'O' Ring Material	Seat Material	Allowable Temperature Limit in °C					
		PTFE/RPTFE		Nylatron		PEEK	
		Low	High	Low	High	Low	High
Nitrile Rubber		-40	121	-40	121	-40	121
VITON Gr. A & B		-25	200	-25	121	-25	200
VITON GLT		-35	200	-35	121	-35	200

NOTE

- Valves can be supplied to NACE MR0175 for sour gas services.
- For other materials of construction, refer to AIL.

42" Class 600 Trunnion Mounted Ball Valve



ASME Classes 150, 300 and 600

Soft Seated and Metal Seated

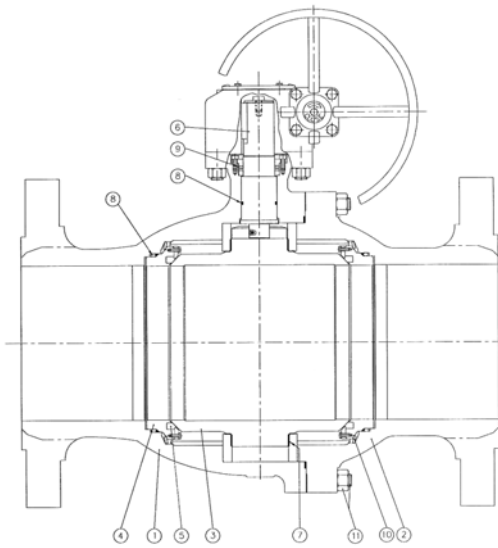

Standard Materials of Construction

Sl.No.	Description	Material
1	Body	ASTM A216 Gr. WCB
2	Body Connector	ASTM A216 Gr. WCB
3	Ball	ASTM A395, ENP coated
4	Seat Housing	SS 4140, ENP coated
5	Seat	PTFE (for soft seated valves)
	Seat Insert	Nylon (for metal seated valves)
6	Stem	SS 410
7	Bearing	Metal-backed PTFE
8	'O' Rings	Nitrile Rubber
9	Packing	Graphite
10	Spring	SS 4140
11	Bolts / Nuts	ASTM A193 B7 / ASTM A194 2H

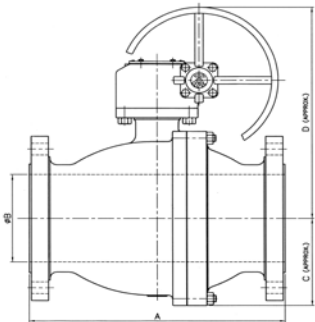

Full Bore Valve

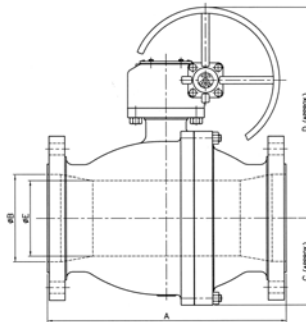

Reduced Bore Valve

For alternate materials of construction, refer page 11

Dimensional Details of Full-Bore Valves (in mm, unless specified)

Valve Size (inches)	Class 150						Class 300						Class 600								
	A		B	C	D	AP WT.(kg.)		A		B	C	D	AP WT.(kg.)		A		B	C	D	AP WT.(kg.)	
	RTJ	RF/BWE				FLG	BWE	RTJ	RF/BWE				FLG	BWE	RTJ	RF/BWE				FLG	BWE
2"	178	216	49	95	170	26	23	216	216	49	75	170	26	23	292	292	49	95	170	31	28
3"	203	283	74	100	200	48	43	283	283	74	100	200	55	49	356	356	74	105	350	63	56
4"	229	305	100	125	285	79	71	305	305	100	130	365	88	79	432	432	100	130	415	112	100
6"	394	457	150	160	420	211	190	403	403	150	165	450	228	206	559	559	150	175	540	308	278
8"	457	521	201	205	570	320	288	502	521	201	220	570	345	311	660	660	201	225	730	488	440
10"	533	559	252	250	610	465	419	568	559	252	255	610	530	477	787	787	252	285	665	747	672
12"	610	635	303	295	665	662	596	648	635	303	300	665	752	677	838	838	303	330	975	1040	936
14"	686	762	334	325	690	865	779	762	762	334	335	980	1007	906	889	889	334	355	1005	1247	1122
16"	762	838	385	365	735	1110	999	838	838	385	370	1015	1297	1167	991	991	385	400	1055	1567	1410
18"	864	914	436	405	950	1443	1299	914	914	436	420	1065	1645	1481	1092	1092	436	445	1100	2203	1983
20"	914	991	487	460	1005	1953	1758	991	991	487	465	1125	2197	1977	1194	1194	487	500	1175	2870	2583
22"	1092	1092	538	480	1130	2473	2226	1092	1092	538	490	1150	2740	2466	1295	1295	538	535	1230	3460	3114
24"	1067	1143	589	530	1175	3073	2766	1143	1143	589	545	1200	3357	3021	1397	1397	589	595	1286	4453	4008
28"	1245	1346	684	605	1230	4425	3983	1346	1346	684	600	1250	5077	4569	1549	1549	684	620	1390	6533	5880
30"	1295	1397	735	635	1280	5230	4707	1397	1397	735	655	1300	5930	5337	1651	1651	735	655	1430	7703	6933
36"	1524	1727	874	725	1390	9070	8163	1727	1727	874	745	1420	9960	8964	2083	2083	874	755	1535	12805	11525
42"	1855	2083	1020	850	1650	12230	11007	2083	2083	1020	850	1645	13140	11826	2437	2437	1020	880	1680	18505	16655
48"	2134	2388	1166	960	1765	20475	18428	2134	2388	1166	975	1785	22230	20007	2540	2540	1166	1005	1815	27905	25115
56"	2489	2489	1360	*	*	31850	28665	2489	2489	1360	*	*	34630	31167	2949	2949	1360	1060	1875	43255	38930

Dimensional Details of Reduced-Bore Valves (in mm, unless specified)

Valve Size (inches)	Class 150								Class 300								Class 600							
	A		B	C	D	E	AP WT.(kg)		A		B	C	D	E	AP WT.(kg)		A		B	C	D	E	AP WT.(kg)	
	RTJ	RF/BWE					FLG	BWE	RTJ	RF/BWE					FLG	BWE	RTJ	RF/BWE					FLG	BWE
2"	178	216	49	95	170	49	26	23	216	216	49	75	170	49	26	23	292	292	49	95	170	49	31	28
3" x 2"	203	283	74	95	170	49	31	28	283	283	74	75	170	49	35	32	356	356	74	95	170	49	41	37
4" x 3"	229	305	100	100	200	74	59	53	305	305	100	100	200	74	66	59	432	432	100	105	350	74	84	75
6" x 4"	394	457	150	125	285	100	158	142	403	403	150	130	365	100	171	154	559	559	150	130	415	100	231	208
8" x 6"	457	521	201	160	420	150	240	216	502	521	201	165	450	150	259	233	660	660	201	175	540	150	366	330
10" x 8"	533	559	252	205	570	201	372	335	568	559	252	220	570	201	424	382	787	787	252	225	730	201	597	538
12" x 10"	610	635	303	250	610	252	525	476	648	635	303	255	610	252	601	541	838	838	303	285	665	252	832	749
14" x 12"	686	762	334	295	665	303	692	623	762	762	334	300	665	303	805	725	889	889	334	330	975	303	1122	1010
16" x 14"	762	838	385	325	690	334	888	799	838	838	385	335	980	334	1037	934	991	991	385	355	1005	334	1253	1128
18" x 16"	864	914	436	365	735	385	1227	1104	914	914	436	370	1015	385	1398	1258	1092	1092	436	400	1055	385	1873	1686
20" x 18"	914	991	487	405	950	436	1660	1494	991	991	487	420	1065	436	1867	1680	1194	1194	487	445	1100	436	2440	2196
22" x 18"	1092	1092	538	405	950	436	2102	1892	1092	1092	538	420	1065	436	2329	2096	1295	1295	538	445	1100	436	2941	2647
24" x 20"	1067	1143	589	460	1005	487	2612	2351	1143	1143	589	465	1125	487	2853	2568	1397	1397	589	500	1175	487	3785	3407
28" x 24"	1245	1346	684	530	1175	589	3761	3385	1346	1346	684	545	1200	589	4315	3884	1549	1549	684	595	1285	589	5553	4998
30" x 24"	1295	1397	735	530	1175	589	4446	4001	1397	1397	735	545	1200	589	5337	4803	1651	1651	735	595	1285	589	6548	5893
36" x 30"	1524	1727	874	635	1280	735	7710	6939	1727	1727	874	655	1300	735	8466	7619	2083	2083	874	655	1430	735	10884	9796
42" x 36"	1855	2083	1020	725	1390	874	10396	9356	2083	2083	1020	745	1420	874	11169	10052	2437	2437	1020	755	1535	874	15729	14156
48" x 42"	2134	2388	1166	850	1650	1020	17404	15663	2134	2388	1166	850	1645	1020	18896	17006	2540	2540	1166	880	1680	1020	23719	21347
56" x 48"	2489	2489	1360	960	1765	1166	27073	24365	2489	2489	1360	975	1785	1166	29436	26492	2949	2949	1360	1005	1815	1166	36767	33090

*8" Full Bore Class 150 Bolted construction
Gear-operated Metal seated
Trunnion Mounted Ball Valve*



ASME Classes 900, 1500 and 2500

Soft Seated

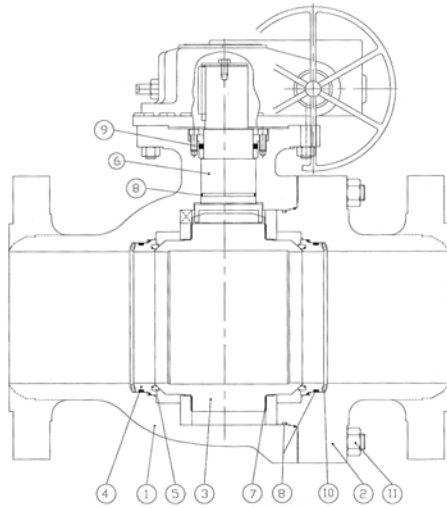

Standard Materials of Construction

Sl.No.	Description	Material
1	Body	ASTM A216 Gr. WCB
2	Body Connector	ASTM A216 Gr. WCB
3	Ball	ASTM A395, ENP coated
4	Seat Housing	SS 4140, ENP coated
5	Seat	Nylon
6	Stem	SS 410
7	Bearing	Metal-backed PTFE
8	'O' Rings	Nitrile Rubber
9	Packing	Graphite
10	Spring	SS 4140
11	Bolts / Nuts	ASTM A193 B7 / ASTM A194 2H

For alternate materials of construction, refer page 11

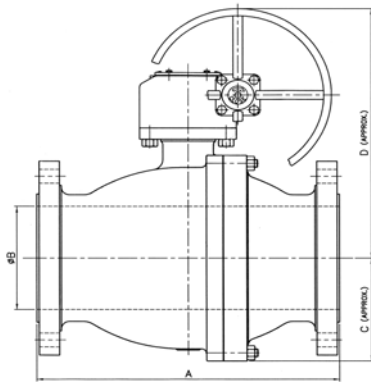

Full Bore Valve

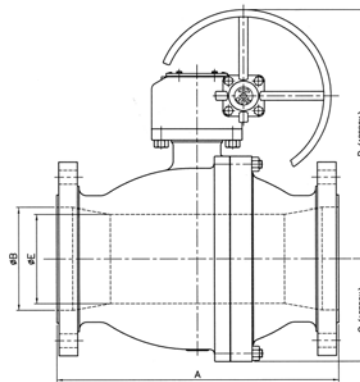

Reduced Bore Valve

Dimensional Details of Full-Bore Valves (in mm, unless specified)

Valve Size (inches)	Class 900						Class 1500						Class 2500								
	A		B	C	D	AP WT.(kg.)		A		B	C	D	AP WT.(kg.)		A		B	C	D	AP WT.(kg.)	
	RTJ	RF/BWE				FLG	BWE	RTJ	RF/BWE				FLG	BWE	RTJ	RF/BWE				FLG	BWE
2"	371	368	49	100	215	56	50	371	368	49	80	215	57	51	454	451	42	110	345	177	159
3"	384	381	74	120	395	83	74	473	470	74	150	430	107	96	584	578	62	145	475	348	313
4"	460	457	100	145	520	174	156	549	546	100	180	550	193	174	683	673	87	215	575	588	529
6"	613	610	150	195	655	402	362	711	705	144	220	680	525	473	927	914	131	260	655	1030	927
8"	740	737	201	230	685	595	536	841	832	192	260	850	798	719	1038	1022	179	335	750	1483	1335
10"	841	838	252	300	705	950	855	1000	991	239	320	1060	1302	1172	1292	1270	223	395	820	2537	2283
12"	968	965	303	320	950	1217	1095	1146	1130	287	425	1130	1912	1721	1445	1422	265	445	890	3793	3414
14"	1038	1029	322	375	960	1603	1443	1276	1257	315	480	1180	2520	2268	1597	1575	279	515	960	5645	5081
16"	1140	1130	373	425	980	2130	1917	1407	1384	360	540	1230	3367	3030	*	*	*	*	*	6160	5544
18"	1232	1219	423	460	1000	2860	2574	1232	1219	407	605	1295	4740	4266	-	-	-	-	-	-	-
20"	1334	1321	471	510	1070	3863	3477	1334	1321	457	695	1380	6460	5814	-	-	-	-	-	-	-
22"	1435	1245	522	520	1115	5373	4836	1296	1296	-	735	1420	8142	5562	-	-	-	-	-	-	-
24"	1568	1549	570	585	1160	7083	6375	1568	1549	534	775	1460	9823	8841	-	-	-	-	-	-	-
28"	1775	1753	665	650	1260	9620	8658	-	-	-	-	-	-	-	-	-	-	-	-	-	-
30"	1902	1880	712	690	1410	13210	11889	-	-	-	-	-	-	-	-	-	-	-	-	-	-
36"	2315	2286	855	800	1530	15700	14130	-	-	-	-	-	-	-	-	-	-	-	-	-	-

* For these dimensions, refer to A11.

Dimensional Details of Reduced-Bore Valves (in mm, unless specified)

Valve Size (inches)	Class 900								Class 1500								Class 2500							
	A		B	C	D	E	AP WT.(kg)		A		B	C	D	E	AP WT.(kg)		A		B	C	D	E	AP WT.(kg)	
	RTJ	RF/BWE					FLG	BWE	RTJ	RF/BWE					FLG	BWE	RTJ	RF/BWE					FLG	BWE
2"	371	368	49	100	215	49	56	50	371	368	49	80	215	49	57	51	454	451	42	110	345	42	177	159
3" x 2"	384	381	74	100	215	49	54	48	473	470	74	80	215	49	70	63	584	578	62	110	345	42	226	203
4" x 3"	460	457	100	120	395	74	130	117	549	546	100	150	430	74	145	130	683	673	87	145	475	62	441	397
6" x 4"	613	610	150	145	520	100	301	271	705	705	144	180	550	100	394	354	927	914	131	215	575	87	773	695
8" x 6"	740	737	201	195	655	150	446	402	832	832	192	220	680	144	599	539	1038	1022	179	260	655	131	1113	1001
10" x 8"	841	838	252	230	685	201	760	684	991	991	239	260	850	192	1041	937	1292	1270	223	335	750	179	2029	1826
12" x 10"	968	965	303	300	705	252	973	876	1130	1130	287	320	1060	239	1529	1376	1445	1422	265	395	820	223	3035	2731
14" x 12"	1038	1029	322	320	950	303	1283	1154	1257	1257	315	425	1130	287	2016	1814	1597	1575	279	445	890	265	4516	4064
16" x 14"	1140	1130	373	375	960	322	1704	1534	1384	1384	360	480	1180	315	2693	2424	-	-	-	-	-	-	5852	5267
18" x 16"	1232	1219	423	425	980	373	2431	2188	1232	1219	407	540	1230	360	4029	3626	-	-	-	-	-	-	-	-
20" x 18"	1334	1321	471	460	1000	423	3284	2955	1334	1321	457	605	1295	407	5491	4942	-	-	-	-	-	-	-	-
22" x 18"	1435	1422	522	460	1000	423	4567	4111	1296	1296	-	605	1295	407	6920	6228	-	-	-	-	-	-	-	-
24" x 20"	1568	1549	570	510	1070	471	6021	5419	1568	1549	534	695	1380	457	8350	7515	-	-	-	-	-	-	-	-
28" x 24"	1775	1753	665	585	1160	570	8177	7359	-	-	-	-	-	-	-	-	-	-	-	-	-	-	-	-
30" x 24"	1902	1880	712	585	1160	570	11229	10106	-	-	-	-	-	-	-	-	-	-	-	-	-	-	-	-
36" x 30"	2315	2286	855	690	1410	712	13345	12011	-	-	-	-	-	-	-	-	-	-	-	-	-	-	-	-

*16" Full Bore Class 900 Welded construction
Gear-operated Soft seated
Trunnion Mounted Ball Valve*



AIL Metal Seated Trunnion Mounted Ball Valves

3-piece fully-welded construction

Standard Features

- **Double-Block and Bleed**
- **Cavity Relief**
- **Blowout-proof stem**
- **Stem Sealing - assured safety**
- **Vent and Drain**
- **Compact Trunnion holder**
- **Valve Ends**
- **Actuator Mounting Flange**
- **Lifting Lugs and Foot Support**
- **Operating Devices**

For details, refer pages 4 and 5.

In addition to the AIL Trunnion Mounted Ball Valve range covering the 2-piece bolted/welded body design, AIL also offers Trunnion Mounted Ball Valves in 3-piece fully welded construction. These are available in sizes from 20" to 56", in pressure ratings of ASME Class 150, Class 300 and Class 600.

As a standard, the valves are offered in full bore (piggable) construction, with reduced bore construction available as an option.

Body Construction

The 3-piece range of AIL metal seated Trunnion Mounted Ball Valves are of fully-welded construction. The body, or the central shell member, is made of rolled and welded rings or ring-forged shells. The end pieces are made of ring-rolled forgings and are welded to the central shell member. The welding is performed by qualified welders and as per qualified welding procedures, in line with ASME codes.

ENP-coated Ball and Seat Rings

ENP coating on the ball enhances the corrosion and erosion resistance property of the ball surface. Likewise, seats are also ENP-coated.

Sealant Injection System

A renewable seal is provided for valves in sizes of 8" and above in the form of a fully-contained sealant injection system, which also serves as an emergency backup in case of damage to other sealing members.

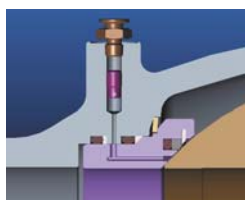

Fire-safe by design

AIL Metal Seated Trunnion Mounted Ball Valves are intrinsically fire-safe by design.

Standards of Conformance

Refer Table on Compliance Standards in page 11.

Optional Features

- **Double-piston Seat design**
- **CE and ATEX marking**
- **'O' Rings with AED properties**
- **Pup-piece/Transition Pipe**
- **Locking and Extension arrangements**

For details, refer page 8.

Pressure Testing

Valve Rating	Shell (hydro)		Seat (hydro)	
	kg/cm ²	psi	kg/cm ²	psi
150	32	450	22	315
300	79	1125	58	815
600	157	2225	115	1630

Optional low pressure AIR SEAT test at 80 psi is conducted, if specifically called for.

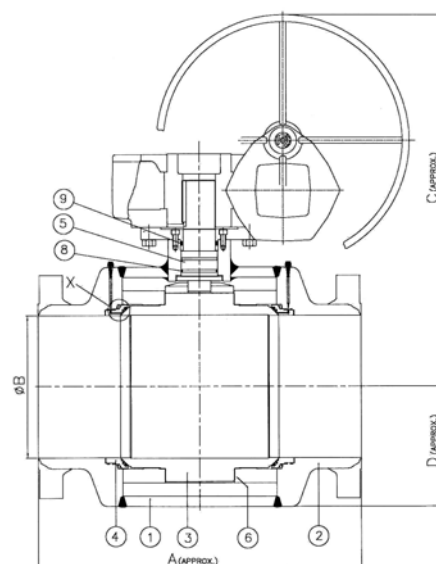

Materials of Construction

Sl. No.	Description	Material	Remarks
1.	Shell	ASTM A516 Gr70/60 ASTM A105 / ASTM A350 Gr. LF2	Seam Weld is 100% Radiographed, in case of rolled and Welded plate, Forged units are Ultrasonically Tested
2.	End Forgings	ASTM A105 / ASTM A350 Gr. LF2	Forgings are Ultrasonically Tested
3.	Ball	ASTM A395 / ASTM A350 Gr. LF2	Ball is coated with PTFE as a standard. ENP coating also done on special request
4.	Seat Ring	ASTM A105 / ASTM A350 Gr. LF2 SS 4140	Seat Ring is coated with PTFE as a standard. ENP coating also done on special request
5.	Stem	SS 4140 with ENP / SS 410	ENP Coating - 25 Microns (minimum)
6.	Bearing	Metal Backed PTFE	
7.	Insert	Nylon Impregnated with MoS ₂	Insert is energised by 'O' Rings
8.	'O' Ring	Nitrile / Viton	
9.	Packing	Graphite	

Optional : Compliance to NACE MR 0175.



16" Reduced Bore Fully-welded construction (Fabricated) Metal seated TMBV

Dimensional Details (in mm, unless specified)

Valve Size	A				B	C (approx)			D (approx)		
	CL. 150		CL. 300	CL. 600		CL. 150	CL. 300	CL. 600	CL. 150	CL. 300	CL. 600
	FLG.	BWE	FLG. & BWE	FLG. & BWE							
20"	914	991	991	1194	487.4	1060	1065	1095	425	430	450
24"	1067	1143	1143	1397	589.0	1150	1155	1270	505	510	530
28"	1245	1346	1346	1549	684.2	1305	1315	1350	575	585	610
30"	1295	1397	1397	1657	735.0	1360	1370	1395	620	630	655
32"	1372	1524	1524	1778	779.5	1385	1400	1430	650	665	690
36"	1524	1727	1727	2083	874.7	1505	1525	1550	725	745	770
40"	1727	1803	1803	2159	976.3	1605	1620	1650	805	820	855
42"	1816	1880	1880	2235	1020.8	1630	1650	1685	850	870	900
48"	2057	2134	2134	2489	1166.8	1765	1785	1815	965	985	1025
56"	2362	2489	2489	2921	1382.7	1990	2015	2060	1130	1155	1200

Valves are optionally available in Reduced Bore design. For sizes other than those listed above, refer to ALL.

Cut-section details of a Trunnion Mounted Ball Valve

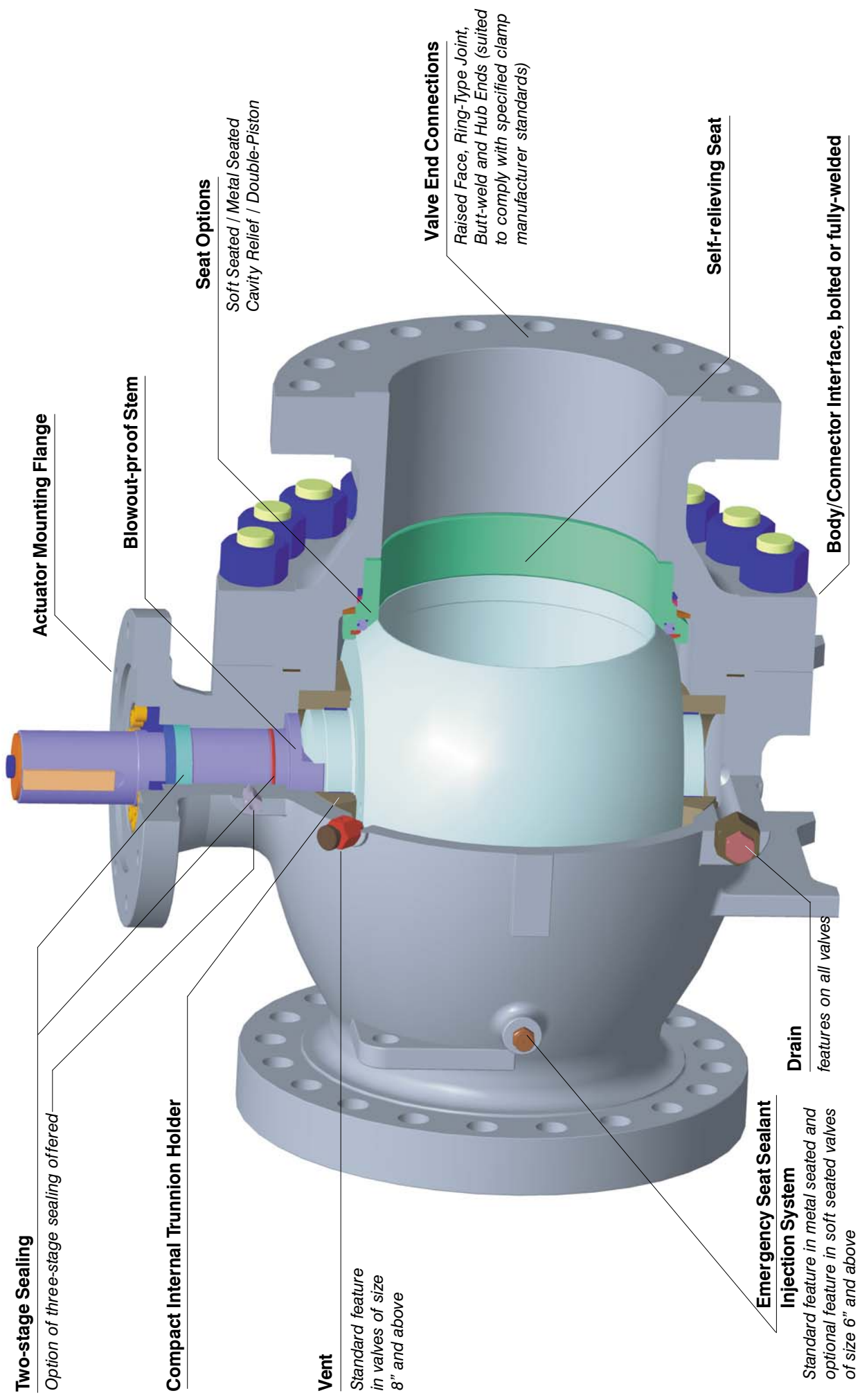

ORDERING INFORMATION

01	02	03	04	05	06
Valve Type	Bore Type	Valve Configuration	Class Rating	Ends	Body and Connector
T - Trunnion Mounted Ball Valve	F - Full Bore R - Reduced Bore	A - Two-piece bolted, Soft Seat B - Two-piece bolted, Metal Seat C - Two-piece Welded, Soft Seat D - Two-piece welded, Metal Seat E - Three-piece bolted, Metal Seat F - Three-piece bolted, Metal Seat G - Three-piece welded, Soft Seat H - Three-piece welded, Metal Seat	2 - CI 150 3 - CI 300 6 - CI 600 9 - CI 900 A - CI 1500 B - CI 2500	33 - Flanged RF 55 - Flanged RTJ 66 - Butt-weld ends 36 - Flanged RF and Butt-weld 56 - Flanged RTJ and But-weld	C - ASTM A216 Gr WCB L - ASTM A352 Gr. LCB F - ASTM A351 Gr. CF8 M - ASTM A351 Gr. CF8M Y - ASTM A351 Gr. CN7M (Alloy 20) D - ASTM A216 Gr. WCC E - ASTM A352 Gr. LCC S - ASTM A890 Gr. 4A (Duplex SS)
07	08	09	10	11	
Ball	Seat Ring	Stem	Operator	Accessories	
A - ASTMA395 + PTFE B - ASTMA395 + ENP C - WCB + PTFE D - WCB + ENP F - CF8 G - CF8 + ENP M - CF8M N - CF8M + ENP I - CA 15 Y - ASTM A351 Gr. CN7M (Alloy 20) J - ASTM A105 + PTFE K - ASTM A105 + ENP S - ASTM A890 Gr. 4A (Duplex SS)	A - SS 4140 + PTFE B - SS 4140 + ENP C - WCB + PTFE D - WCB + ENP F - CF8 G - CF8 + ENP M - CF8M N - CF 8M + ENP O - ASTM A395 + PTFE H - ASTM A395 + ENP J - ASTM A105 + PTFE K - ASTM A105+ ENP S - ASTM A890 Gr. 4A (Duplex SS) Y - Alloy 20 P - PTFE R - RPTFE E - PEEK L - Nylon	A - SS 410 B - SS 4140 + ENP F - SS 304 M - SS 316 Y - ASTM A351 Gr. CN7M (Alloy 20) P - ASTM A564 TR630 (17-4PH) K - BS 3076 NA18 (Monel 500) S - ASTM A182 Gr. F51	G - Gear Unit N - Bare Shaft W - Wrench (not provided) L - Wrench (provided) E - Electrical Actuator P - Pneumatic Actuator O - Gas-over-Oil Actuator T - Gas type Actuator	Ex - Extension Spindle L - Locking Device S - Special	



Kancheepuram plant



Maraimalai Nagar plant



AUDCO INDIA LIMITED

Administrative Office

Mount-Poonamallee Road, Manapakkam, Post Bag 976, Chennai 600 089, INDIA.

Tel : (044) 22492323. Fax : (044) 22495055, 22494055.

Website : www.ailvalves.com

Manufacturing Plants

- Mount-Poonamallee Road, Manapakkam, Chennai 600 089, INDIA.
- Enathur, Kancheepuram 631 552, INDIA.
- B8, MMDA Industrial Area, Maraimalai Nagar 603 209, INDIA.
- Malumichampatti, Coimbatore 641 021, INDIA.

Marketed by

LARSEN & TOUBRO LIMITED

Valves Business Unit

Post Bag 5247, Chennai 600 002, INDIA. Tel : (044) 28462015-19. Fax : (044) 28462102/03.

PO. Box 619, Kolkata 700 071, INDIA. Tel : (033) 22822435/22823301. Fax : (033) 22828406.

PO. Box 8901, Mumbai 400 072, INDIA. Tel : (022) 28581118/28581432. Fax : (022) 28581027.

PO. Box 6223, New Delhi 110 015, INDIA. Tel : (011) 51419579-83. Fax : (011) 51419596.

Cover picture
12" Reduced Bore Class 1500
Bolted construction
Gear-operated Soft seated
Trunnion Mounted Ball Valve

